

#12/11 Stacked Valve – DC Unit Layout

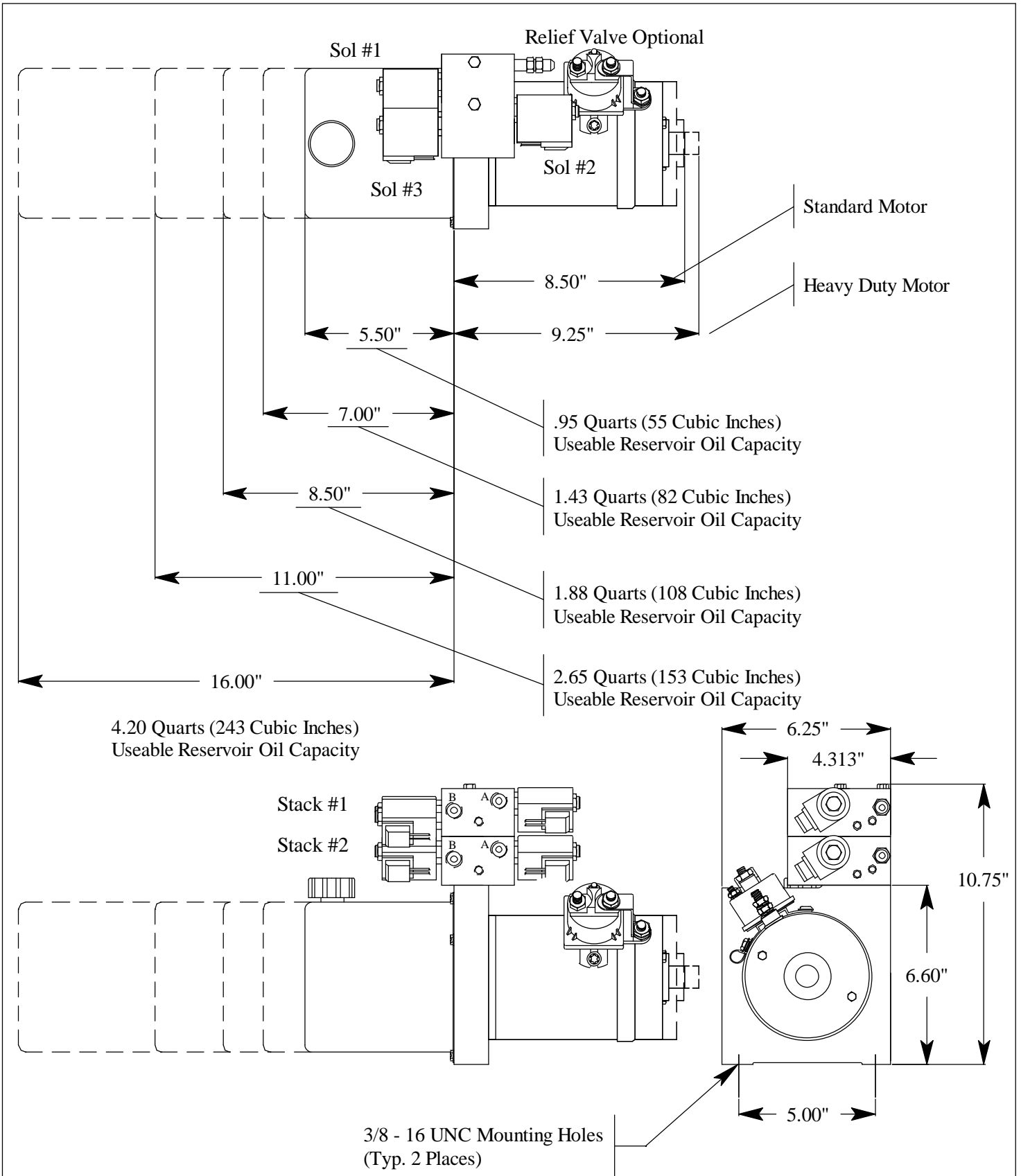

Description :

12 Volt DC Piston/Gear Pump Unit with One #12 Valve & One #11 Valve Stacked. One 4-Way, 2-Position Solenoid Valve and Two Solenoid Operated N/C Check Valves in Stack #1 as well as Optional Cross-Port Relief Valves. Stack #2 has One 4-Way, 2-Position Solenoid Valve and One Solenoid Operated N/C Check Valve.

#12/11 Stacked Valve – Schematic

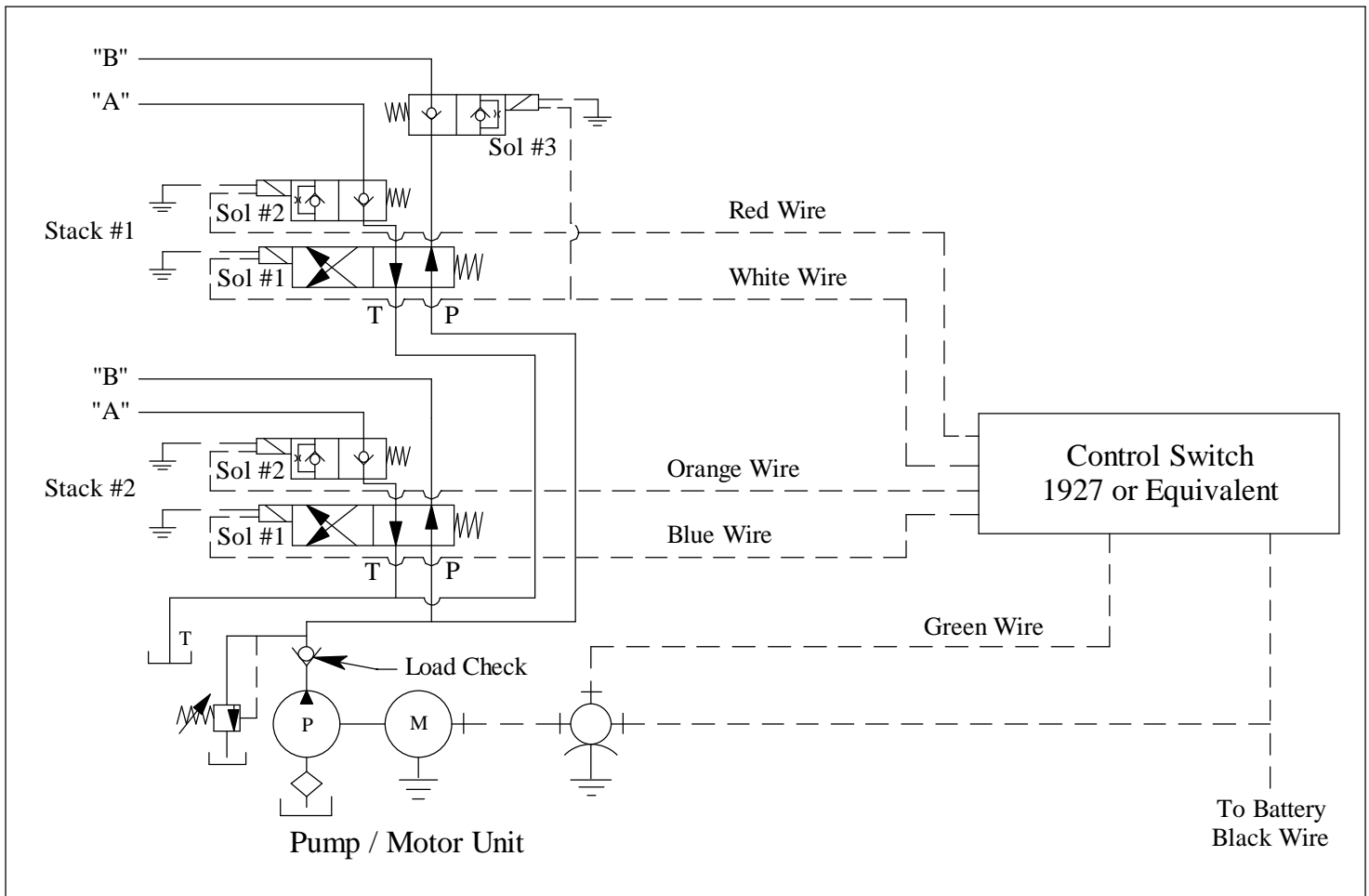

System Function

On Stack #1, energizing power unit, Sol #1, and Sol #3, oil is directed to port "A" and oil from port "B" is directed back to tank ("T" port). Energizing power unit, and Sol #2, oil is directed to port "B" and oil from port "A" is directed back to tank ("T" port).

On Stack #2, energizing power unit and Sol #2, oil is directed to port "B" and oil from port "A" is directed back to tank ("T" port). Energizing power unit and Sol #1, oil is directed to port "A" and oil from port "B" is directed back to tank ("T" port).

Application

1. Power up / Power Down (Stack #2)
2. Power extend / Gravity down (Stack #1)

Note :

When either one of the valves are actuated, both hoses of the other valve will pressurize. This is normal in this design.

Valve Characteristics

1. Uses one 4-way, 2-position spool type cartridge valve and two 2-way NC P.O. poppet type cartridge valves, solenoid operated in Stack #1.
2. Uses one 4-way, 2-position spool type cartridge valve and one 2-way NC P.O. poppet type cartridge valves, solenoid operated in Stack #2.
3. Aluminum manifold block machined for one 4-way, 2-position cartridge valve, two 2-way cartridge valves and with two 3/8" NPT Ports.
4. On stack #1, "B" port relief is plugged. In applications where a low pressure relief is required, a #24 valve is recommended.

Limitations (Each Valve Stack)

1. When lifting and/or holding a load, use port "A".
2. If valves are used in an application in which a cylinder is to be lowered with a load on it (over-riding load), it should be noted that pressure surges can occur in the load holding hose on the valve that is being operated.
3. Horizontal Mounting.