

NOTICE: This manual is to remain with truck after pump unit is installed.

Williams®

MACHINE & TOOL

Hydraulic Power Units

Instructions for Williams® Hydraulic Power Units

DC 3-Piston Pumps

DC Split-Flow Piston Pumps

DC 6-Piston Pumps

DC Gear Pumps

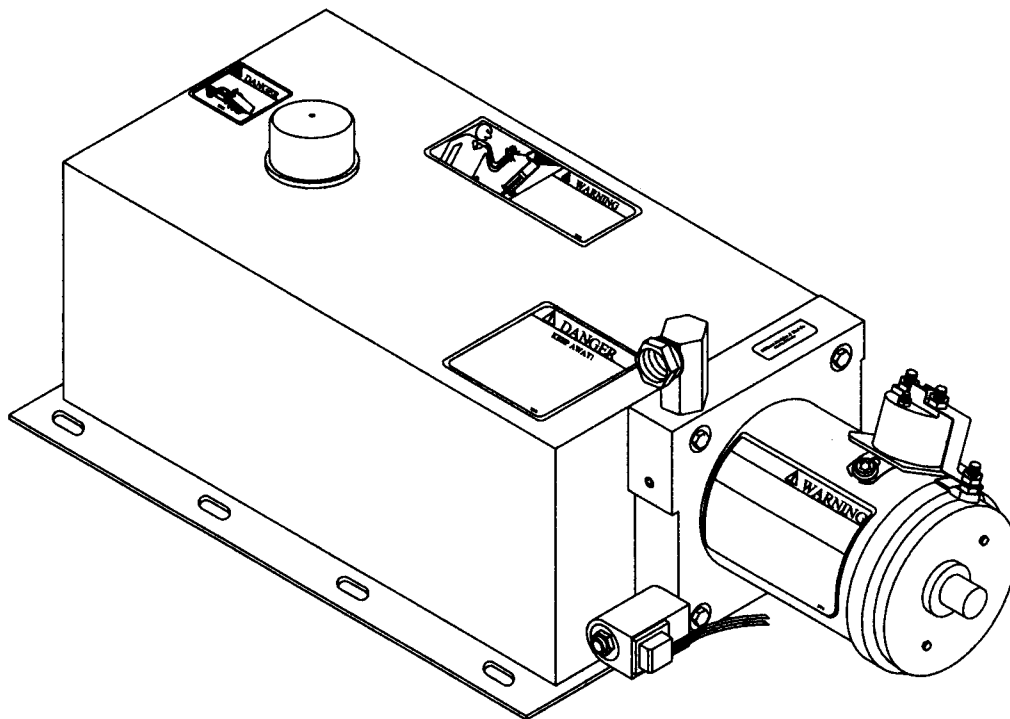

Williams® Machine & Tool

204 Plastic Lane

Monticello, IA 52310-9472 USA

Phone: (319) 465-3537

Fax: (319) 465-5279

E-mail: Info@energymfg.com

Web Site: www.williamsmachineandtool.com

Pump Serial No. _____

Pump Model No. _____

READ & UNDERSTAND THIS MANUAL BEFORE ATTEMPTING MAINTENANCE OR REPAIR

To the Owner/Operator:

Read this manual thoroughly. The information presented in this manual will assist you to install, operate, and service a hydraulic power unit. Keep this manual with the unit at all times.

Throughout this manual you will see the following safety alert symbols:



This symbol indicates a personal safety hazard. Become alert, your safety is involved.



Indicates a potentially hazardous situation, which, if not avoided, may result in moderate injury.



Indicates a potentially hazardous situation, which, if not avoided, could result in death or serious injury.



Indicates an imminently hazardous situation, which, if not avoided, will result in death or serious injury.

General Information

The purpose of this manual is to assist the owner/operator in maintaining and operating Williams® Machine & Tool hydraulic power units. Read it carefully before attempting operation, maintenance, or repair.

Checklist

Pre-Use Checklist

- Before operating hoist, check the hoist manufacturer's recommended maximum payload. Do not overload the hoist.
- Read and understand all the safety decals and signs on the truck hoist and Williams® Machine & Tool hydraulic power units.
- Make sure that the hoist body prop and pump unit are in place and operational before attempting to operate the hoist.

General Checklist Before Use

- Before operating a loaded truck body, make sure the truck is on level, firm ground.
- Before operating the truck hoist, check to make sure the area is clear of all personnel and equipment.
- Operate the hoist controls from the cab during dumping operations. Release tailgate controls before lifting the body.

Safety Decals

1. Read and understand this manual and obey all safety decals before operating the hydraulic power unit.
2. Never go under a truck box, loaded or unloaded, unless the truck box has been properly blocked/braced.
3. Before operating a truck hoist, check to make sure the area is clear of all personnel and equipment.
4. Never reach over the truck frame unless the truck box is properly blocked/braced.
5. Never drive the truck unless the truck box is completely lowered.



Williams® p/n 1842



Williams® p/n 1840

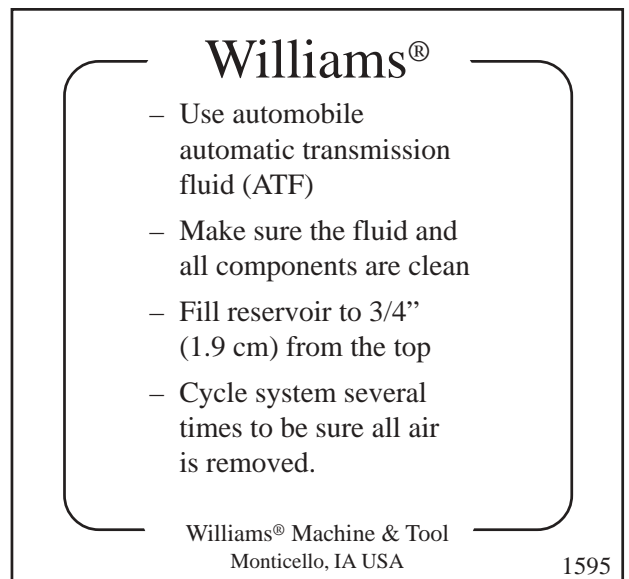

Williams® p/n 1595

Safety Decals

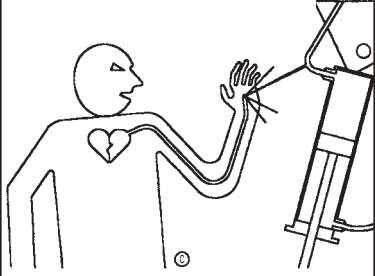
	! WARNING
	<p>DO NOT GO NEAR LEAKS!</p> <ul style="list-style-type: none">• High pressure oil easily punctures skin causing serious injury, gangrene or death.• If injured, seek emergency medical help. Immediate surgery is required to remove oil.• Do not use finger or skin to check for leaks.• Lower load or relieve hydraulic pressure before loosening fittings. <p>1858</p>

Williams® p/n 1858

! WARNING
<p>DO NOT OPERATE PUMP UNIT UNTIL THE FOLLOWING STANDARDS ARE MET:</p> <ul style="list-style-type: none">• USE 00 POWER CABLE ON LENGTHS UP TO 10 FEET (3.05 M) FROM BATTERY.• USE 000 POWER CABLE ON CABLE LENGTHS 11 TO 20 FEET (3.35 TO 6.1 M) FROM BATTERY.• MOUNT PUMP UNIT TO THE VEHICLE WHERE A GROUND EQUAL TO OR LARGER THAN THE POWER CABLE IS MAINTAINED BETWEEN THE PUMP MOUNTING SURFACE AND THE VEHICLE ENGINE BLOCK (CHECK GROUND CONTINUITY BEFORE OPERATING PUMP). (REFER TO INSTALLATION INSTRUCTIONS FOR FURTHER IMPORTANT INFORMATION)*
<p>FAILURE TO MEET THESE STANDARDS:</p> <ul style="list-style-type: none">• MAY RESULT IN SEVERE INJURY OR DEATH.• WILL VOID PUMP UNIT WARRANTY.• MAY CAUSE DAMAGE TO THE VEHICLE AND/OR VEHICLE ELECTRICAL SYSTEM.
<p>WILLIAMS® MACHINE & TOOL IS NOT RESPONSIBLE FOR PERSONAL INJURY, DEATH OR VEHICLE AND/OR EQUIPMENT DAMAGE.</p>
<p>REPLACEMENT INSTALLATION INSTRUCTIONS AND/OR DECALS AVAILABLE FROM:</p> <p>WILLIAMS® MACHINE & TOOL 204 Plastic Lane • Monticello, IA 52310-9472 USA Phone: (319) 465-3537 • Fax: (319) 465-5279 E-mail: Info@energymfg.com Web Site: www.williamsmachineandtool.com</p> <p>1974</p>

Williams® p/n 1974

Safety Decal Locations

(See pages 3 & 4 for decal details and text)

DC electric pump units on square/round reservoirs
(Solenoid operated control valves)

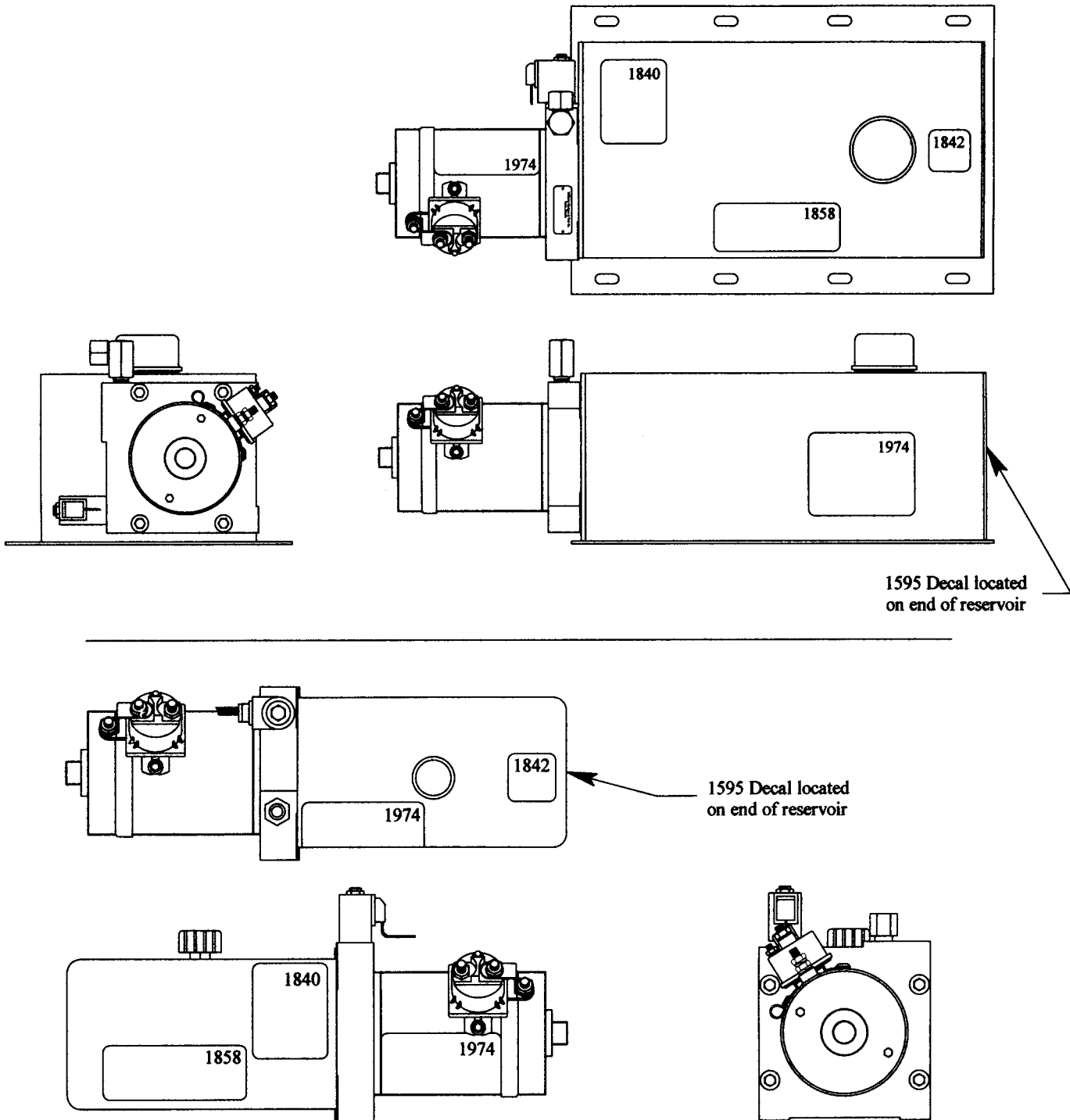

Installation/Replacement Instructions



DANGER

Before beginning installation work, make sure the truck box is empty and properly blocked/braced. Always disconnect hydraulic hoses from the valve to hoist cylinder after the truck box is properly blocked/braced. Serious injury or death will result from truck box falling in one second or less.

1. Fabricate the necessary hardware and bracketry to install the hydraulic power unit to the truck frame. Ensure that a ground is maintained between the hydraulic power unit and the vehicle that is equal to or larger than the main power cable. (Reference Note below on grounding.)



CAUTION

Failure to maintain an adequate ground between the hydraulic power unit and the truck frame may result in damage to the hydraulic unit and/or the vehicle electrical system.

2. Install hydraulic hoses from the control valve to the hoist cylinder. Use hydraulic hoses with a pressure rating equal to or greater than the pressure at which the system will be operating. Information sheets for determining lift and lower ports for the control valve have been included with the unit.
3. Install switch cord from the hydraulic power unit to the cab of the truck. Route the cord around all hazards which may damage the cord such as catalytic converters, exhaust manifolds, mufflers, etc. Make sure the cord is not crushed, pinched or the outer casing is damaged. Use tie downs to properly secure the cord.
4. To ensure proper wiring, valve schematics have been included with this book to show proper wiring diagrams for the switch and control valves.
5. Install the main power cable to the starter solenoid on the motor of the hydraulic power unit.
Note: Do not attach the power cable to the main power source (battery) at this time.
Use 00 power cable on lengths up to 10 feet (3.05 m) from the battery to the power unit.
Use 000 power cable on lengths from 11 to 20 feet (3.35 to 6.1 m) from the battery to the power unit.

NOTE: A ground equal to or larger than the power cable is required between the hydraulic power unit and the vehicle. (Check for continuity before operating unit.) If the hydraulic power unit is attached to the vehicle frame, it may be required that a separate ground cable be mounted between the hydraulic power unit and vehicle engine block. This requirement is necessary due to some vehicle frames having a protective coating which does not allow for an adequate ground.

6. Fill reservoir 3/4" (1.9 cm) to 1" (2.5 cm) from the top. Use a premium fluid for hydraulic systems. We recommend automobile ATF (Automatic Transmission Fluid). These fluids provide good seal compatibility, protection against wear, ample rust protection and excellent anti-foam properties.
7. Check unit for proper wiring and grounding. Ensure switch is wired per the included sheets.
8. Attach the power cable to the power source.
9. Check to make sure all persons and/or all equipment is clear of the area before operating the truck hoist. Do not attempt any repairs or adjustments to the truck hoist, truck box or hydraulic power unit until the truck box is properly blocked/braced.

Operating Instructions



DANGER

Never go under a raised truck box, unless the truck box is properly blocked/braced. Serious injury or death will result from truck box falling in one second or less.

To Raise a Load:

1. Release the tailgate controls before raising the truck load.
2. From inside the cab, push the switch towards the up/raise position. When the truck box is at the appropriate height, release the switch.
3. Dump a loaded box slowly. Be careful the load does not shift rapidly.
4. Do not drive the truck while the truck box is raised.

To Lower a Load:

1. From inside the cab, push the switch towards the down/lower position. When the box is at the appropriate height, release the switch.
2. Do not drive the truck while the truck box is raised.

Charging a Hydraulic System

Single Acting Cylinder Applications:

The reservoir must be sized to handle the full displacement of the lifting end of the cylinder. Fill the reservoir 3/4" to 1" (1.9 to 2.5 cm) from the top when the cylinder is completely retracted.

Double Acting Cylinder Applications: Without Recycle Capabilities

The reservoir must be sized to handle the full displacement of the lifting end of the cylinder. Fill the reservoir 3/4" to 1" (1.9 to 2.5 cm) from the top when the cylinder is completely retracted.

Double Acting Cylinder Applications: With Recycle Capabilities

The reservoir can be sized to handle the total displacement of the cylinder rod only. To charge a reservoir on a recycle application, follow the steps below:

1. Fill the reservoir 1" (2.5 cm) from the top when the cylinder is completely retracted.
2. Operate the pump for a short time to extend the cylinder. Do not run the reservoir dry as this will introduce air into the system.
3. Properly block/brace the truck box. Never go under the truck box unless it is properly blocked/braced.
4. Again, fill the reservoir 1" (2.5 cm) from the top. Repeat steps 2,3, and 4 until the cylinder is completely extended.
5. Retract the cylinder completely and adjust the fluid level inside the reservoir 3/4" to 1" (1.9 to 2.5 cm) from the top.

NOTE: Never fill the reservoir completely when the cylinder is even slightly extended. The reservoir will overflow with fluid when it is retracted.



CAUTION

Used hydraulic fluid is considered hazardous waste in some states. If used fluid is spilled, check your local regulations for proper handling & cleaning procedures.

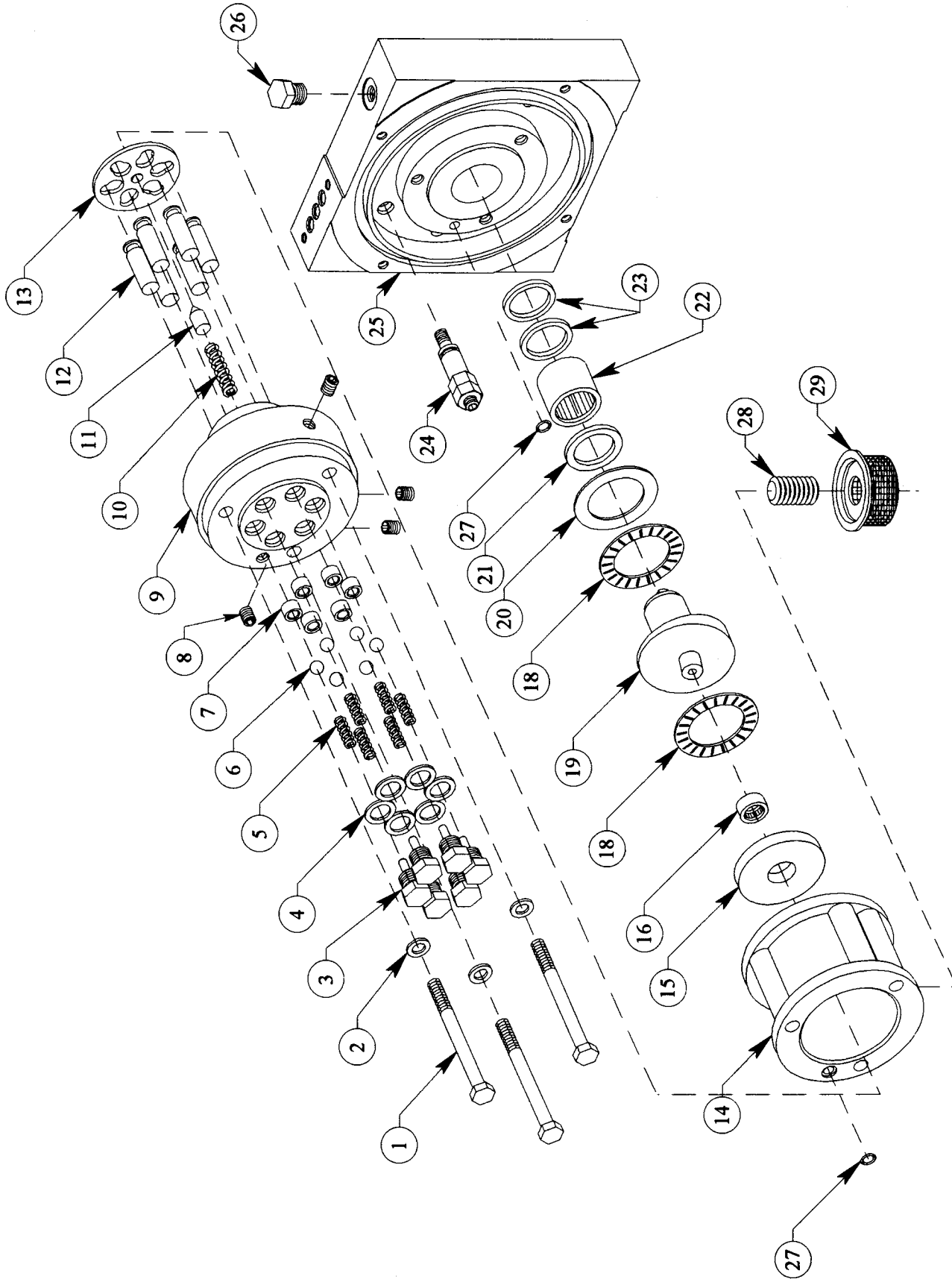

6 Piston Pump and Manifold Assembly

6 Piston Pump and Manifold Assembly Parts List

Item	Part No.	Quantity Req'd	Part Description
1	1857	3	Cap Screw, 5/16" - 18 x 4-1/2", GR5
2	1030	3	Washer, 21/64" ID Alum.
3	1008	6	Port Stud w/Pin
4	1009	6	Washer, 1/16" Thk 1/2" ID Alum.
5	2264	6	Spring, Long Exhaust Port Stud
6	1015	6	Bearing, 5/16" Chrome Ball
7	1636	6	Seat, Electric Pump
8	1579	4	Plug, 1/16" NPT w/Sealant
9	2004	1	Casting Machined, 6 Piston (Not Sold Separately)
10	1642	1	Spring, Return Plate Pivot
11	1635	1	Pivot, Piston Return Plate
12	1633	6	Piston (Not Sold Separately)
13	1973	1	Plate, Piston Return E6P HT
14	1998	1	Intake Housing, Machined
15	1637	1	Thrust Plate, Piston
16	1643	1	Bearing, B85
18	1644	2	Bearing, Thrust Roller
19	1632	1	Wobble, Electric Pump
20	1645	1	Race, Thrust 1/16" TRB 2233
21	1638	1	Spacer, Bearing 1" ID
22	1023	1	Bearing, B1616
23	1028	2	Oil Seal, CR9815 Type VC
24	1588	1	Relief Assembly, Pump
25	—	1	Manifold, Machined
26	1399	1	Port Stud, No Pin
27	21616A	2	O-Ring, 3/8" OD x 1/4" ID x 1/16" Thk (2-010)
28	1765	1	Nipple, 3/8" NPT x Close
29	1744	1	Screen, Intake

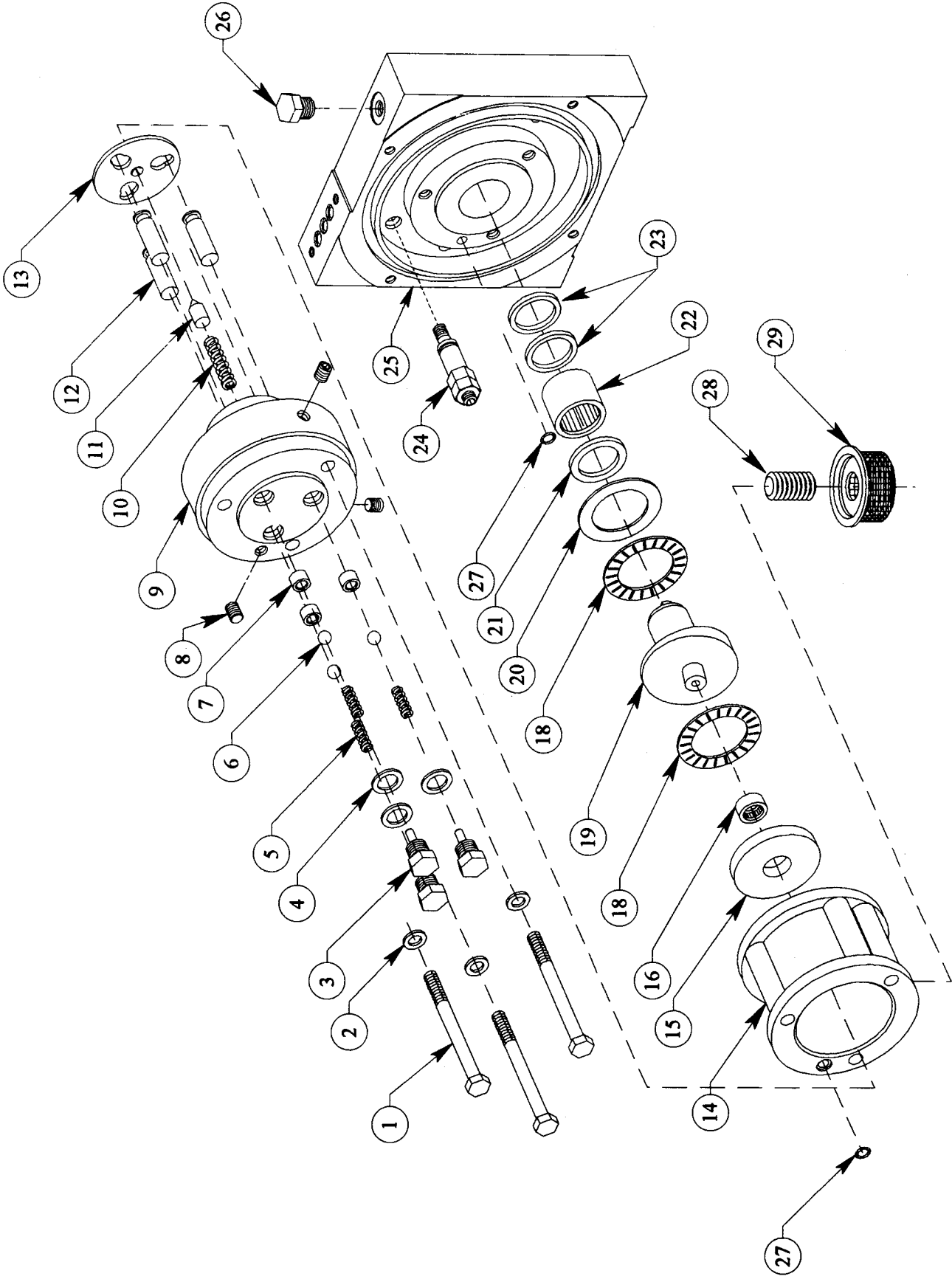

3 Piston Pump and Manifold Assembly

3 Piston Pump and Manifold Assembly Parts List

Item	Part No.	Quantity Req'd	Part Description
1	1857	3	Cap Screw, 5/16" - 18 x 4-1/2" (G5)
2	1030	3	Washer, 21/64" ID Alum.
3	1008	3	Port Stud w/Pin
4	1009	3	Washer, 1/16" Thk 1/2" ID Alum.
5	2264	3	Spring, Long Exhaust Port Stud
6	1015	3	Bearing, 5/16" Chrome Ball
7	1636	3	Seat, Electric Pump
8	1579	3	Plug, 1/16" NPT w/Sealant
9	1855	1	Casting Machined, 3 Piston (Not Sold Separately)
10	1642	1	Spring, Return Plate Pivot
11	1635	1	Pivot, Piston Return Plate
12	1633	3	Piston (Not Sold Separately)
13	1634	1	Plate, Piston Return
14	1998	1	Intake Housing, Machined
15	1637	1	Thrust Plate, Piston
16	1643	1	Bearing, B85
18	1644	2	Bearing, Thrust Roller
19	1632	1	Wobble, Electric Pump
20	1645	1	Race, Thrust 1/16" TRB 2233
21	1638	1	Spacer, Bearing 1" ID
22	1023	1	Bearing, B1616
23	1028	2	Oil Seal, CR9815 Type VC
24	1588	1	Relief Assembly, Pump
25	—	1	Manifold, Machined
26	1399	1	Port Stud, No Pin
27	21616A	2	O-Ring, 3/8" OD x 1/4" ID x 1/16" Thk (2-010)
28	1765	1	Nipple, 3/8" NPT x Close
29	1744	1	Screen, Intake

Electric Motor Assembly

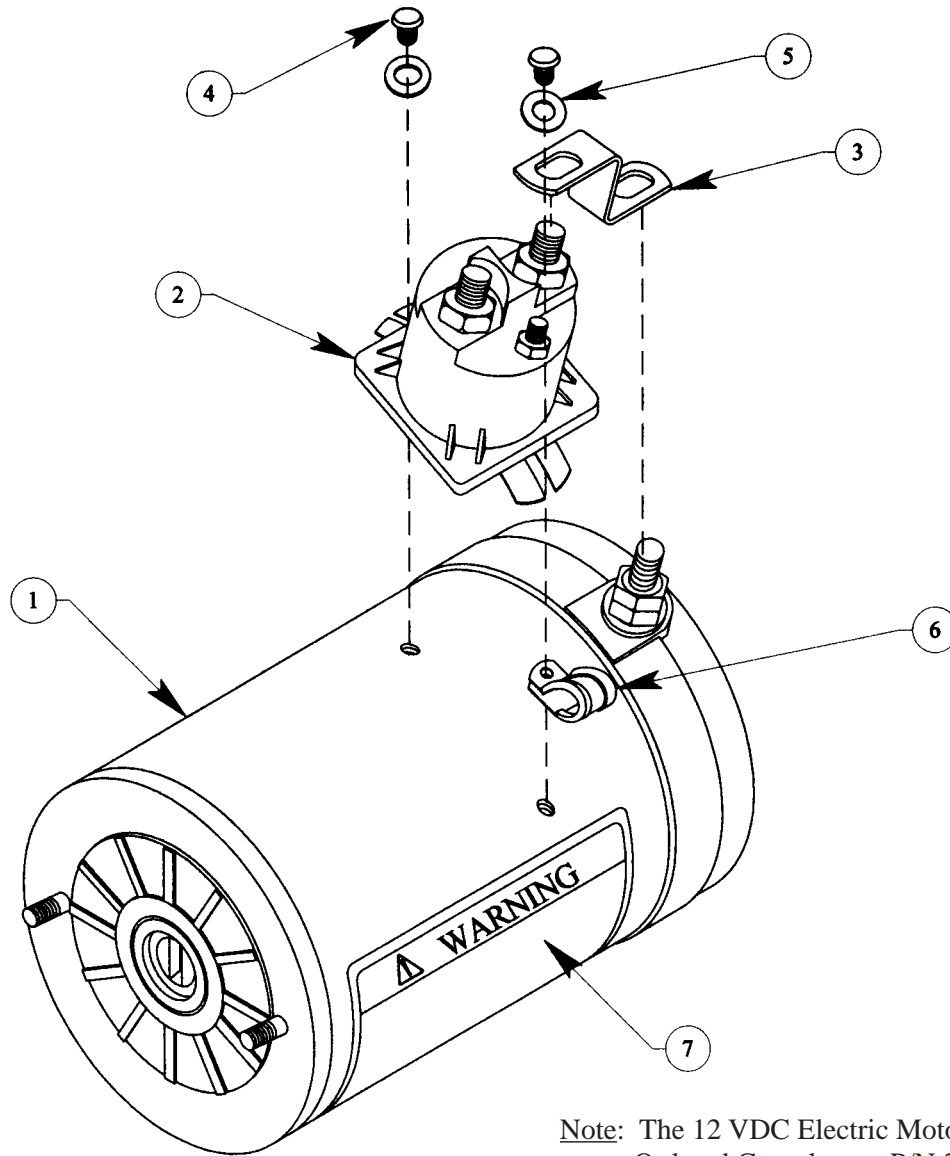

Note: The 12 VDC Electric Motor Assembly Can Be Ordered Complete as P/N 2654

Drawing No.	Part No.	Quantity Req'd	Part Description
1	2613	1	DC Motor
2	2521	1	Solenoid, 12 VDC Phenolic
3	2511	1	Copper Strap
4	—	2	10-32 x 9/32" Thread Roll T25 Torx Drive
5	1805	2	Washer, 1/4" ID x 5/8" OD Plain
6	2066	1	Clamp, 3/8"
7	1974	1	Decal, Warning: Wire Size Reqm.
Not Shown	2656	1	Terminal Ring (#10)

Square Electric Reservoir Assembly

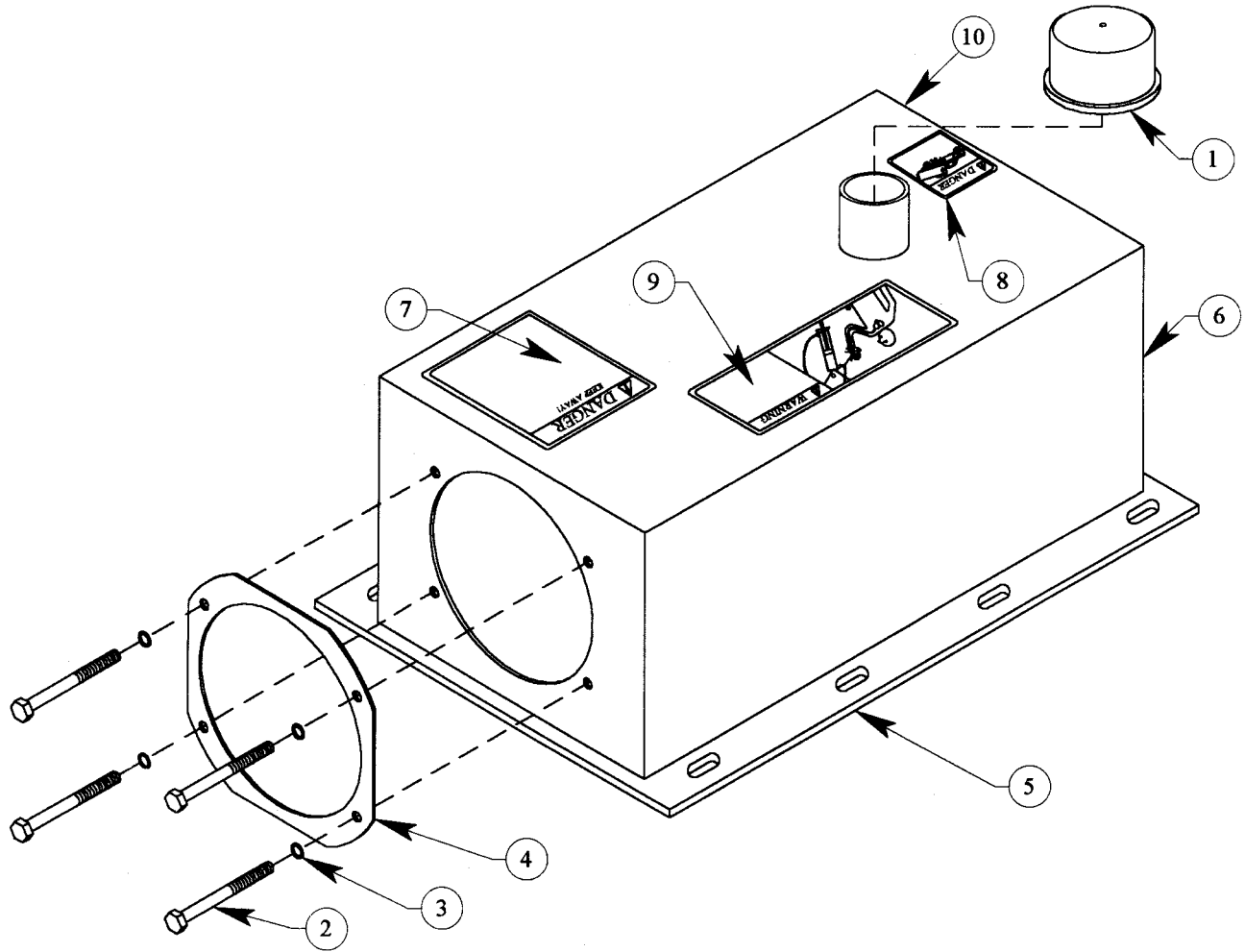

Drawing No.	Part No.	Quantity Req'd	Part Description
1	1013	1	Breather Cap
2	1938	4	Cap Screw, 1/4-20 x 2" GR 8 HH
3	2493	4	Washer, Aluminum 1/4" x 5/8" OD
4	2491	1	Gasket, Electric Reservoir
5	—	1	Reservoir, Square Electric
6	1595	1	Sticker, Info (Electric)
7	1840	1	Sticker #1, Wording w/Address
8	1842	1	Sticker #3 Small Truck Picto
9	1858	1	Warning Label, 2" x 5-1/4"
10	1974	1	Decal, Warning: Wire Size Req'm.

Round Electric Reservoir Assembly

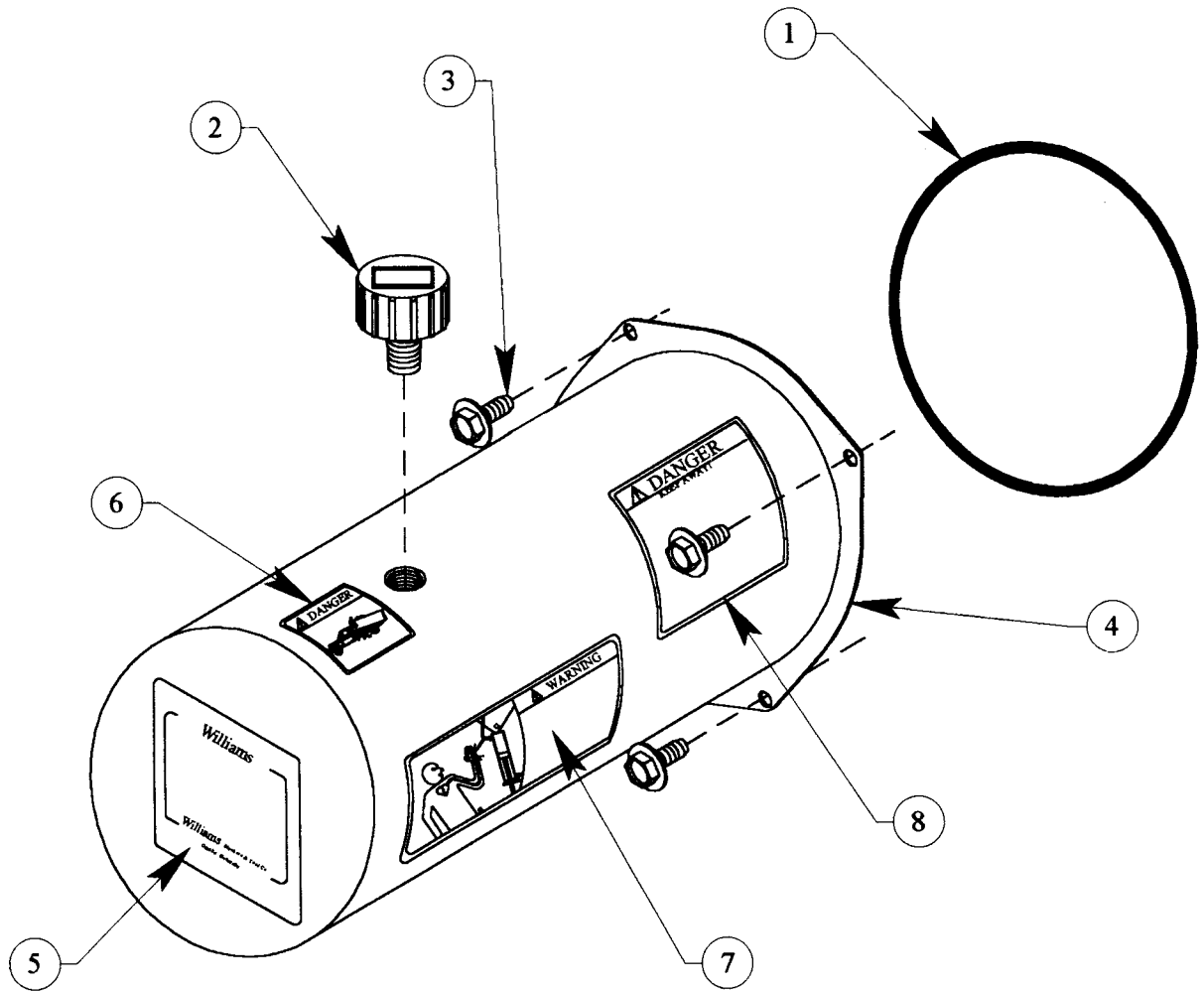

Drawing No.	Part No.	Quantity Req'd	Part Description
1	1605	1	O-Ring, 5-1/2" ID
2	1589	1	Breather Cap
3	1126	4	Screw, 1/4-20 x 1/2" Thread Roll
4	—	1	Reservoir, Round Electric
5	1595	1	Sticker, Info (Electric)
6	1842	1	Sticker #3, Small Truck Picto
7	1858	1	Warning Label, 2" x 5-1/4"
8	1840	1	Sticker #1, Wording w/Address

Warranty

Subject to the limitations of warranty below, Williams® Machine & Tool (Williams®) warrants its products against substandard materials and/or workmanship for one year from date of manufacture. Williams® will, at its sole option, either repair or replace any warranted product or part proven to be substandard in material and/or workmanship. Normal in-service wear of products or components is not covered by this warranty.

Written authorization from Williams® for return of substandard products must be obtained prior to return shipment. Any alleged substandard products shall be shipped to Williams®, freight prepaid by the shipper, along with a complete explanation of the alleged defect. Substandard items must be returned to Williams® within 30 days of receiving written authorization for return. If the products returned are found not to be substandard, the owner/shipper shall be responsible for and shall pay Williams® normal repair charges.

Unless specifically stated in writing, Williams® products are not recommended for high cycle industrial use, for use on aircraft, for use in lifting people, or for any use that may place people in a dangerous position during normal use.

Limitations of Warranty

Williams® does not warrant any product for a specific use, unless so stated in writing. The purchaser of any Williams® product is responsible for testing of such product for all matters concerned with its use, including but not limited to safety testing, endurance testing, and performance testing. The purchaser is further responsible for determining if the product is suitable for the purchaser's use or application.

The above specified warranty is the sole warranty extended by Williams®, and there are no other warranties, express or implied, of any type, including but not limited to warranties for merchantability, fitness for a particular purpose, or otherwise. Except as otherwise specified above, Williams® shall in no event be liable for any damages, including but not limited to consequential or incidental damages, cost of labor or repairs, freight charges, injuries to the person or property of buyer or others, machine downtime, loss of profits, loss of time incurred by buyer, or any other damages arising from use of Williams® products or from the warranty.

This warranty specifies the entire warranty of Williams® and there are not other oral or written warranty statements, representations, warranties or guarantee of any agent, officer, employee, manufacturer or seller which is binding on Williams®. In order for purchaser to have any claim for breach of the above-stated express warranty, the purchaser must give notice to Williams® of a breach of this warranty within thirty (30) days from date of discovery of such breach. As stated in the first paragraph, above, in no event shall the warranty against substandard materials and/or workmanship extend beyond one year from date of manufacture.

**Williams®
Machine & Tool**

Williams® Machine & Tool
204 Plastic Lane • Monticello, Iowa 52310-9472 USA
Phone: (319) 465-3537 • Fax: (319) 465-5279
E-mail: Info@energymfg.com
Web Site: www.williamsmachineandtool.com